

Abdominal/Back Extension

Owner's Manual

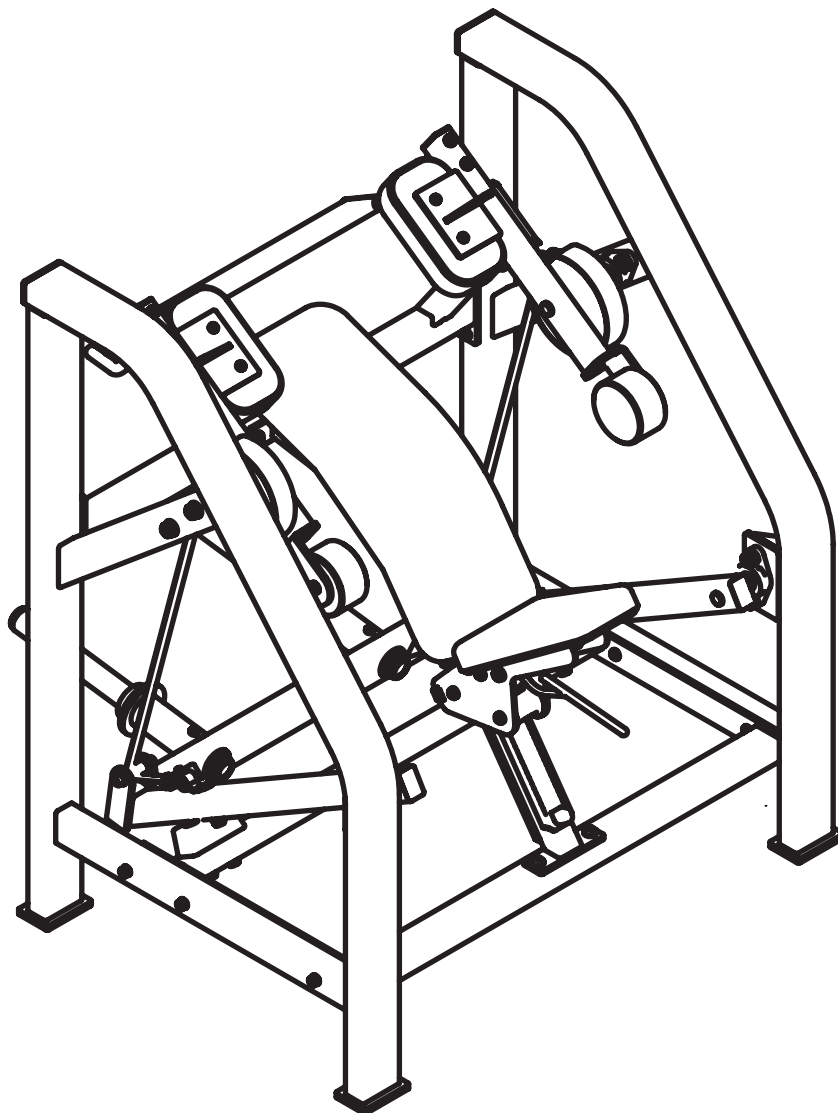

CAUTION

Read all precautions and instructions in this manual before using this equipment. Keep this manual for future reference.

Table of Contents

| | |
|--|----|
| Important Safety Guidelines for Owners | 01 |
| Assembly Instructions | 02 |
| Exploded Diagram | 03 |
| Part List | 04 |
| Assembly Guide | 05 |
| Daily Inspection | 07 |
| Weekly Inspection | 08 |
| Monthly Inspection | 09 |

Important Safety Guidelines for Owners

Follow these guidelines to maintain proper working condition of the equipment:

Important: *Do not modify the equipment or any of its parts, or permanently remove any part from the equipment. Do not use accessory attachments that are not recommended by ours as such attachments might cause injuries.*

- Qualified technicians must perform all regular maintenance.
- Make sure that trainers, facility personnel, and maintenance technicians understand how to use the equipment, know important safety guidelines, and can recognize potential problems such as a worn cable or cracked weld.
- Strength training requires a significant focus by the facility and its staff to maintain the quality of the fitness environment. If possible, the facility should provide direct supervision of the fitness equipment at all times by people knowledgeable about the safe operation of the equipment and trained to recognize potential problems.
- Make sure the equipment is stable and placed on a solid, level surface. The equipment is designed to be freestanding; however, equipment can be bolted to the floor for extra stability. Consult a qualified general contractor for proper fastening methods.
- Make sure that the equipment is installed with enough free space for safe operation. With most equipment, the general rule is to allow about a 4-foot (1.2-meter) circle of space from the user's center. For Functional Training equipment, make sure that the operating space is large enough to allow the cables to be fully extended in all possible directions.
- Check the equipment thoroughly based on the recommended inspection schedules outlined in this manual, including daily, weekly, monthly and annual checks.
- Place an "out-of-order" sign on the equipment during maintenance of the equipment or the surrounding area. Users should never be allowed to operate the equipment until it has been inspected and works properly. If a piece of equipment needs service, keep it out of use until repaired.
- Whenever a weight can drop and hit a user, such as with an Olympic bench, We highly recommends that a helper or spotter be used.
- Do not place the equipment outdoors or on wet surfaces.

Assembly Instructions

Assembly of the *machine* takes about 120 minutes to complete. If this is the first time you have assembled this type of equipment, plan on allowing more time.

Be careful to open boxes and assemble components in the sequence presented in this manual.

Note: With so many assembled parts, proper alignment and adjustment is critical. While tightening the fasteners, be sure to leave room for adjustments.

Open the Box

Use wire cutters to open the box and remove the packing materials.

The illustration shows how the machine will look when you have completed its assembly. The callouts identify specific pieces.

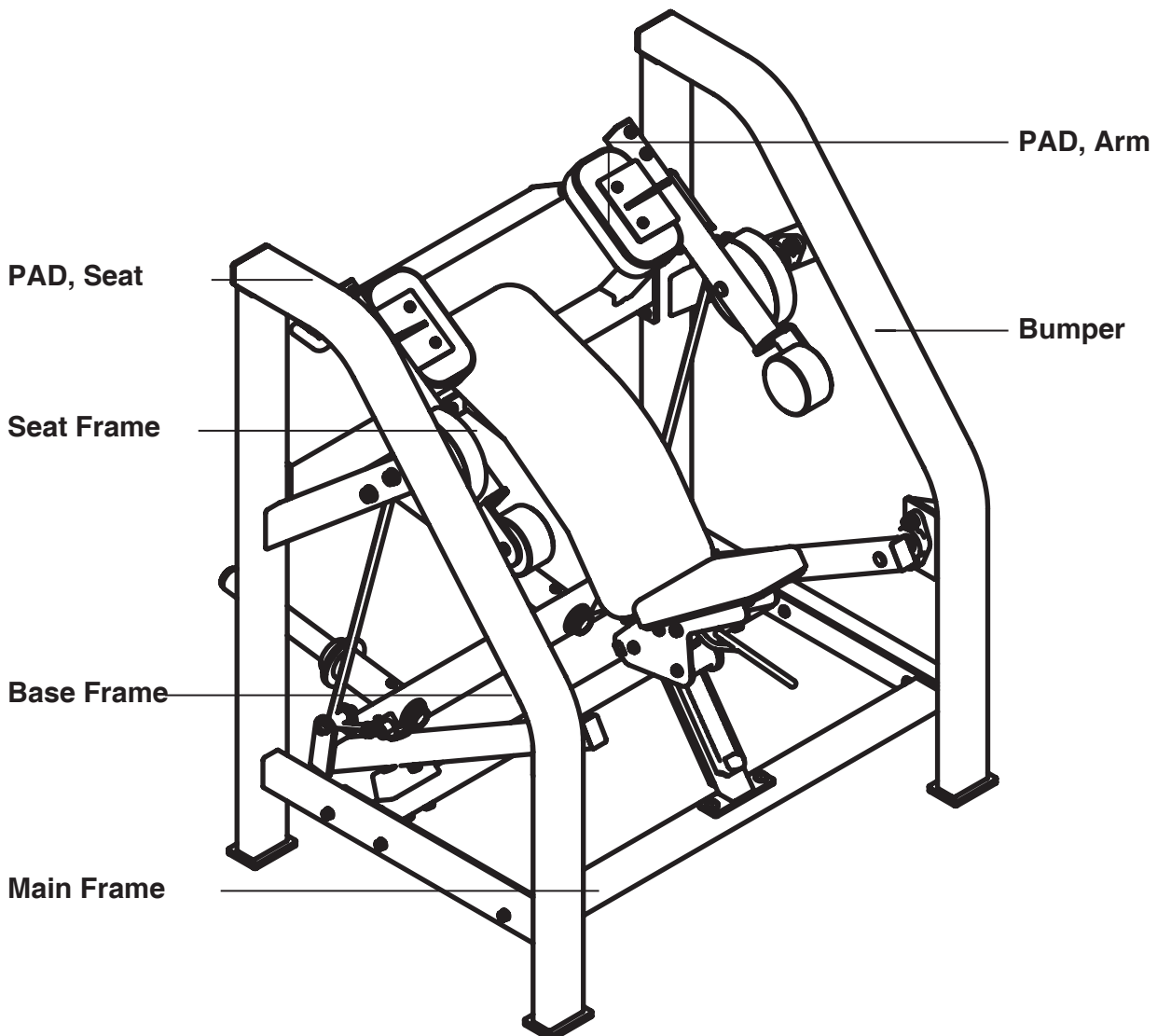

Exploded Diagram

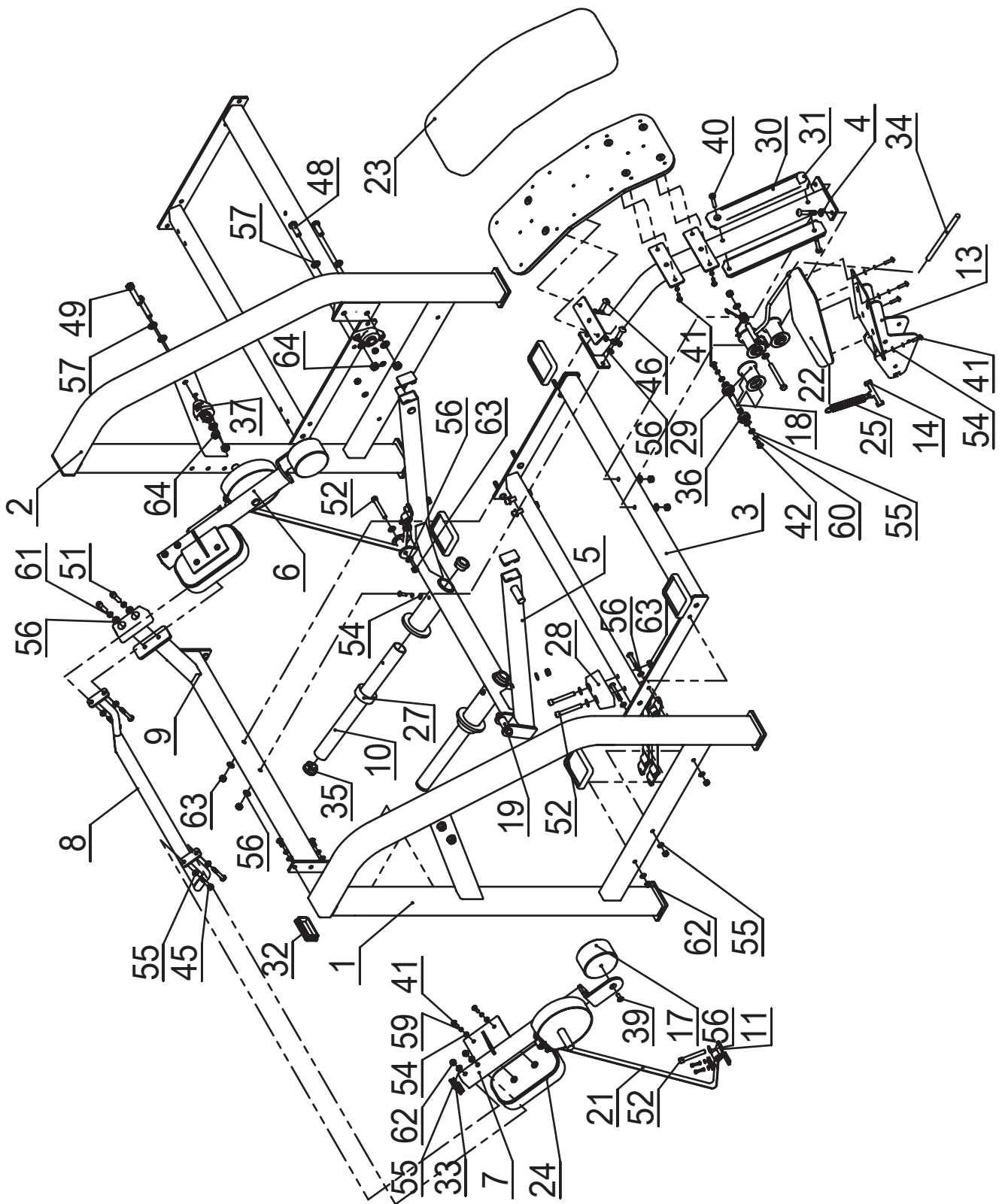

Part List

| ITEM NO. | Description | PART NO. | QTY |
|----------|--------------------|----------------|-----|
| 1 | Upright Frame RT | FL1814-01-00 | 1 |
| 2 | Upright Frame LT | FL1814-02-00 | 1 |
| 3 | Base Crossbar Down | FL1814-03-00 | 1 |
| 4 | BackFrame | FL1814-04-00 | 1 |
| 5 | Swinging Rack | FL1814-05-00 | 1 |
| 6 | Rotational Stand | FL1814-06-00 | 1 |
| 7 | Rotational Stand | FL1814-07-00 | 1 |
| 8 | Base Crossbar Up | FL1814-08-00 | 1 |
| 9 | Base Crossbar Back | FL1814-09-00 | 1 |
| 10 | Barbell Tube | FL1814-10-00 | 2 |
| 11 | Fixed Frame | FL1814-11-00 | 4 |
| 12 | Adjustable Frame | G161-000005 | 1 |
| 13 | Seat Frame | G161-000008 | 1 |
| 14 | Hanging Plate | G101-001190 | 1 |
| 15 | Plate | G101-002636 | 4 |
| 16 | Plate | G101-002668 | 4 |
| 17 | Balance Iron | G102-000039 | 2 |
| 18 | Spindle | G102-000475 | 3 |
| 19 | Rotating Sleeve | G102-000854 | 2 |
| 20 | Plate | G301-000261-04 | 1 |
| 21 | Safety Belt | FL1814-12-00 | 2 |
| 22 | PAD, Seat | G301-000173 | 1 |
| 23 | PAD, Back | G301-000261 | 1 |
| 24 | PAD, Arm | G301-000262 | 2 |
| 25 | Extension Spring | G106-000007 | 1 |
| 26 | Torsion Spring | G106-000009 | 1 |
| 27 | Bumper | G201-000018 | 2 |
| 28 | Bumper | G201-000055 | 2 |
| 29 | Wheel | G202-000159 | 3 |
| 30 | Hanging Plate | G202-000160 | 2 |
| 31 | Stop Block | G202-000165 | 2 |
| 32 | Tube Cap | G202-000179 | 2 |
| 33 | Tube Cap | G202-000182 | 4 |
| 34 | The Armrest Gloves | G202-000294 | 1 |
| 35 | Tube Cap | G202-000355 | 4 |
| 36 | Bearing | G506-6203ZZ | 6 |
| 37 | Bearing | G506-UCFL205 | 4 |
| 38 | Circlip | G506-ZD16-B | 6 |
| 39 | Chamfer Head Screw | CN10-25 | 2 |
| 40 | Chamfer Head Screw | CN10-65 | 2 |
| 41 | Umbrella Head Bolt | STN8-30 | 16 |
| 42 | Umbrella Head Bolt | STN10-20 | 6 |
| 43 | Umbrella Head Bolt | STN10-25 | 6 |
| 44 | Umbrella Head Bolt | STN10-70-25 | 6 |
| 45 | Umbrella Head Bolt | STN10-80-25 | 4 |
| 46 | Umbrella Head Bolt | STN12-70-25 | 4 |
| 47 | Hex head bolt | WLJ12-110-25 | 1 |
| 48 | Hex head bolt | WLJ16-45 | 4 |
| 49 | Hex head bolt | WLJ16-80-25 | 4 |
| 50 | Cylinder Head Bolt | YZN6-20 | 8 |
| 51 | Cylinder Head Bolt | YZN12-45-25 | 2 |
| 52 | Cylinder Head Bolt | YZN12-85-25 | 8 |
| 53 | Flat Washier | PD6 | 8 |
| 54 | Flat Washier | PD8 | 16 |
| 55 | Flat Washier | PD10 | 32 |
| 56 | Flat Washier | PD12 | 28 |
| 57 | Flat Washier | PD16 | 16 |
| 58 | Spring Washier | TD6 | 8 |
| 59 | Spring Washier | TD8 | 16 |
| 60 | Spring Washier | TD10 | 12 |
| 61 | Spring Washier | TD12 | 2 |
| 62 | Lock Nut | NM10 | 10 |
| 63 | Lock Nut | NM12 | 13 |
| 64 | Lock Nut | NM16 | 8 |

Assembly Guide

Step 3

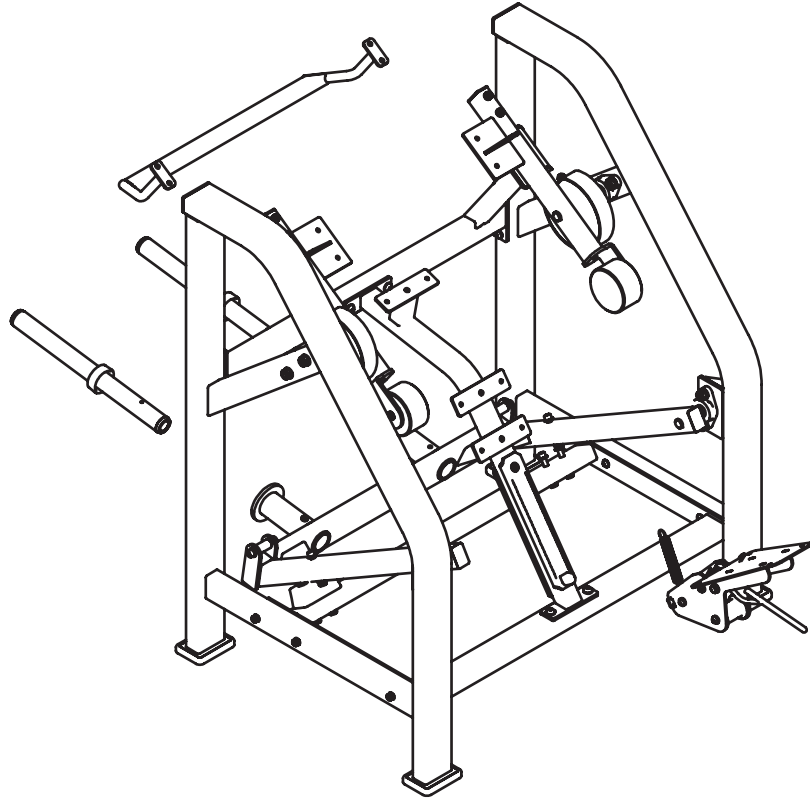

Step 4

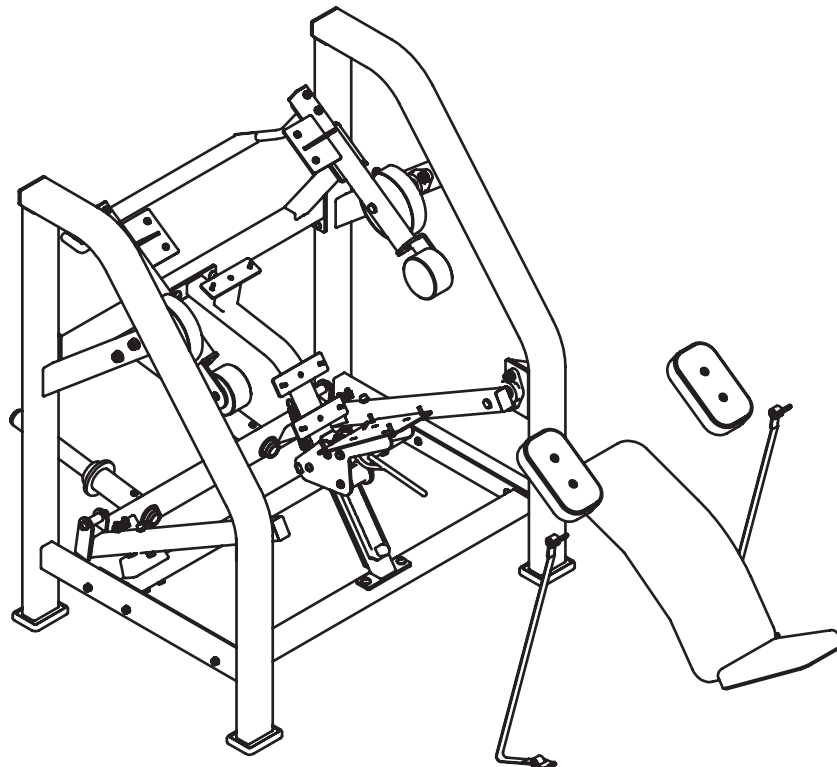

Daily Inspection

You will need to do the following tasks each day to maintain the equipment and keep it operating smoothly and safely. Each of these tasks is covered in this section. You should perform those tasks that are appropriate for the equipment you are maintaining, and skip those tasks that do not apply.

- Inspect cables and end connections for wear.
- Clean and inspect equipment frames.
- Check warning labels and Instruction placards for readability.
- Clean any upholstery on the equipment.
- Inspect pads for wear.

Clean Upholstery

Clean upholstery daily with a mild soap and water solution in a spray bottle. Lightly spray upholstered surfaces and wipe dry with a clean cloth. Cleaning upholstery daily removes surface dirt and perspiration.

Important: *To clean the upholstery, do not use cleaning products that have any of these ingredients: solvents, alcohol, ammonia, and petroleum. Use a mild detergent-based cleaner instead.*

Inspect Pads for Wear

Inspect pads for cracks in the upholstery, loose staples, and loose mounting bolts. Replace pads as needed (refer to Obtaining Service to purchase new pads).

Clean and Inspect Frames

Clean frames daily with a mild soap and water solution in a spray bottle. Wipe the equipment down with a damp cloth and dry completely. Be sure to wipe down both painted parts and chrome parts. Cleaning frames daily removes any grease and dirt.

For chrome parts, use a commercial chrome cleaner to restore and maintain the luster.

As you clean, inspect the frames for cracks, rust, or other damage. Make sure welds are solid and fasteners are properly secured.

Weekly Inspection

This section covers the tasks you should do each week to maintain the equipment. Choose the appropriate tasks for your equipment, depending on what you are maintaining:

- Condition and deep clean upholstery.
- Clean and lubricate cable rod ends.
- Clean and lubricate guide rods.
- Inspect cables, connections, and tension.
- Inspect cable handle attachments.
- Inspect pulleys.
- Inspect each weight stack and selector pin.
- Inspect and lubricate bearings and bushings.
- Check seat adjustment and test pop pins.

Clean Upholstery

Clean upholstery daily with a mild soap and water solution in a spray bottle. Lightly spray upholstered surfaces and wipe dry with a clean cloth. Cleaning upholstery daily removes surface dirt and perspiration.

Important: *To clean the upholstery, do not use cleaning products that have any of these ingredients: solvents, alcohol, ammonia, and petroleum. Use a mild detergent-based cleaner instead.*

Clean and Lubricate Cable Rod Ends

Check cable rod ends to ensure the shoulder bolt is secure. If cable rod ends are noisy, you can lubricate them with a silicone spray lubricant. Spray the lubricant onto the joint where the spherical portion is enclosed in the outer housing. Wipe off any excess lubricant with a rag.

Clean and Lubricate Guide Rods

Inspect the exposed areas of the guide rods for cleanliness. Using a dry cloth, wipe any buildup of dirt or grease from the rods.

Lubricate the exposed areas of the guide rods by applying a light coat of a silicone spray lubricant. Spray the silicone lubricant on a rag and then wipe the guide rods with the rag. Be careful with any lubricant spray; it can stain carpet and clothing.

CAUTION: Do not attempt to lubricate the guide rods when the equipment is in use. Attempting to lubricate between the weight plates without completely disassembling the stack will result in serious injury.

Important: Do not use petroleum-based lubricants or motor oil.

These lubricants tend to cause a rapid buildup of dirt and hair on the weight plates, which can cause the plates to stick together.

Monthly Inspection

Each month, the following tasks should be performed to maintain the equipment. Choose the appropriate tasks based on what you are maintaining.

- Inspect frames and movement arms.
- Lubricate pop pins.
- Check and lubricate ratcheting seat lever
- Inspect all fasteners.

Inspect Frames and Movement Arms

Inspect frames and movement arms monthly for proper function and integrity. Check for cracks, chipped paint, or rust.

Touch up dings and chips in the paint as needed. Replace any component at first signs of wear.

Inspect frames for cracks particularly at the joints. If any cracks are found, immediately take the equipment out of service, and repair it using a qualified maintenance technician. Refer to Important Safety Guidelines and Obtaining Service).

To remove surface rust from the frame, rub lightly with a fine wet/dry sand paper or fine steel wool. Maintain paint luster with an application of a mild automotive wax product.

To maintain the powder coated and chrome parts, use a mild detergent-based cleaner for light dirt and grime removal.

For removing heavier dirt and grease and for polishing, use a good car polish. For scuffs and marks that are not removed by the above methods, use a soft scrub cleanser. Do not use solvents, lacquer thinner, acetone, or finger nail polish remover.

