

MULTI-FUNCTIONAL ALL-IN-ONE VERSATILE UNIT

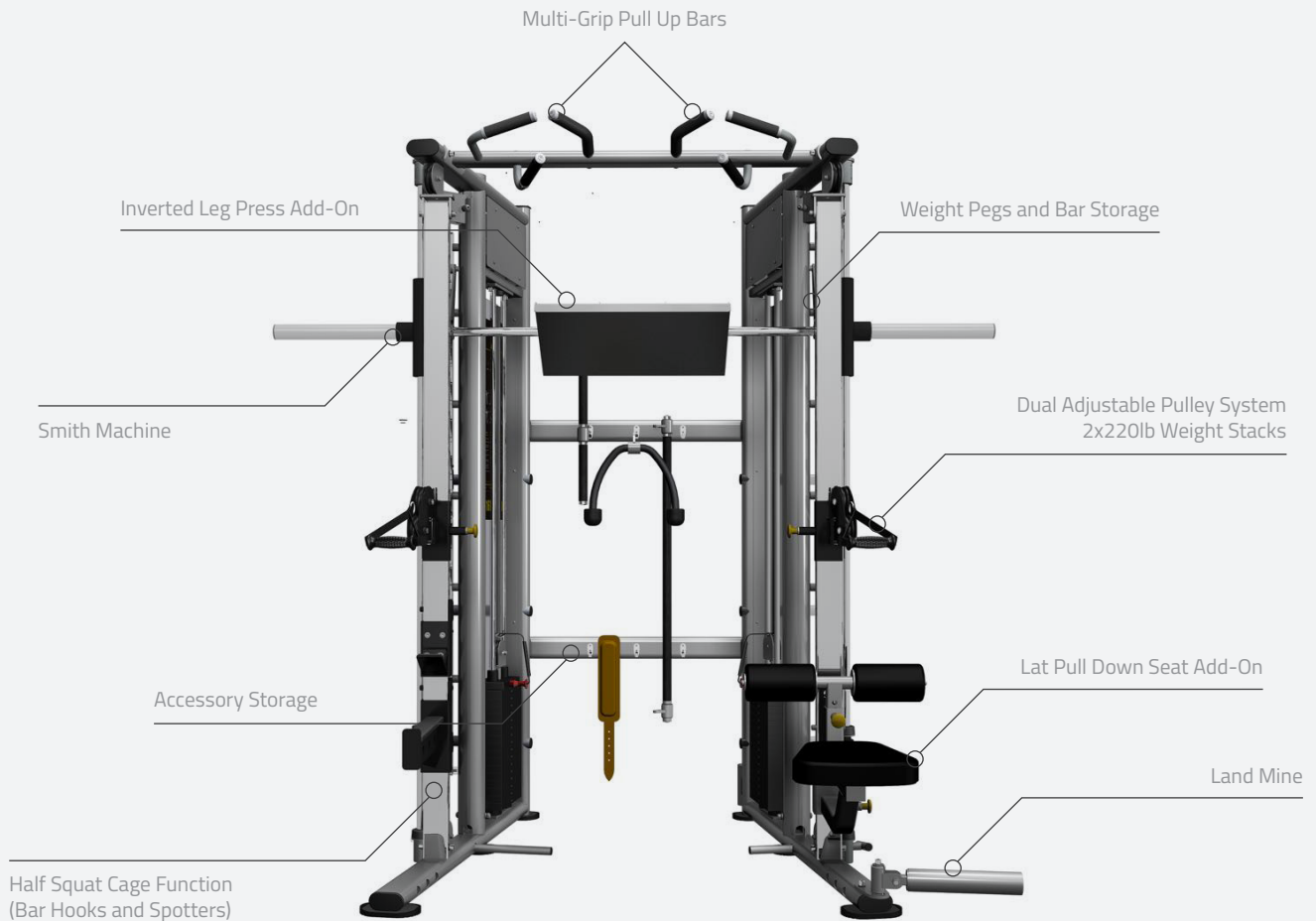

Like its name, The Universal Trainer is truly an all-in-one training system. This inviting apparatus reinvents a piece of equipment we have grown familiar with and adds a natural feeling that compliments the body's movement. The Universal Trainer's innovative space saving design takes multiple pieces of equipment and combines it into a single all-in-one unit. Whether its free weights, resistance training through cable resistance, body weight movements or heavy leg presses, this is a one of a kind machine that can be the sole piece of equipment for any facility.

PRODUCT SPECIFICATIONS	
Assembled Dimension	(LWH) 64.5"x90.3"x90.4"
Product Weight	595lb
Weight Stack	220lb x 2
Frame Color	Silver and Black optional

UNIVERSAL TRAINER

ALL-IN-ONE TRAINING SYSTEM

BODYKORE



Laser cut holes and numbers made with precision.



Multi-Grip pull up handles to target different areas of the back



The inverted leg press add-on attachment allows the users to use the smith bar for inverted less presses.



The dual balanced smith machine spotters make the Universal trainer a safety first training system



The Dual's Adjustable Pulley System comes with 2x220lbs stack weights and storage hooks for the pulley attachments.



6 attachment hooks for storing cable attachments



Safety spotter attachment for Olympic bars.

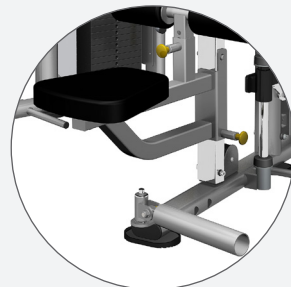

The versatility is endless on the Universal Trainer with a Lat Pull Down Seat attachment and Land Mine.

BODYKORE INC.



7466 Oranewood Ave
Garden Grove, CA 92841
USA

T 949-325-3088
E sales@bodykore.com
W Bodykore.com